

Electronic Smoothcut™ Roll Towel Dispenser

Sensor dispensing with manual override technology

KEY OPERATING FEATURES

- No Touch:** Hygienic hands-free operation
- Cutting System:** Patented Smoothcut™ with adjustable delay, paper length, and sensing range
- Paper Mode:** Exposed or Hidden
- Activation:** Electronic with manual override
- Manual Override:** Push bar or turn knob options

CAPACITY

- Roll Width:** Standard 8.0" (203mm); accommodates from 7.5" to 8.25" (191mm to 210mm)
- Roll Diameter:** Up to 8" (203mm)
- Sheet Length:** Adjustable to 8" (203mm); 10" (254mm) and 12" (305mm)

CONSTRUCTION

- Roll Holder:** Proprietary options
- Modularity:** Interchangeable with mechanical Smoothcut module
- Locks:** Push button, "T-Key", or proprietary keys
- Material:** Impact and chemical resistant plastic

ADDITIONAL FEATURES

- Easy load battery box (4 D-cell batteries)
- AC adaptable
- Custom branding options available



AS108-00
Push Bar



AS108-00
Turn Knob



Leading edge EMS (Electronic Modular Smoothcut) module incorporates patented optical sensing and manual override technology for the industry's broadest range of customized dispensing options

AS108-00

Electronic Smoothcut™ Roll Towel Dispenser

Hygienic hands-free operation with the wide array of custom-dispensing options

Dispenser Specifications:

Finish/Color: White cover and back housing
Black cover and back housing
Smoke or clear window options

Manual overrides: Push bar override shown;
turn knob also available

Dispenser Dimensions

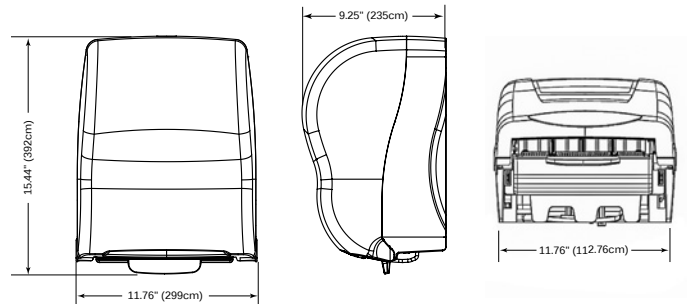

Paper Specifications:

Paper Capacity: 1 roll + stub roll
Roll Width: 7.5-8.25" (191-210mm)
Roll Diameter: 8.0" (203mm)
Roll Sheet: 8", 10", 12" (203mm, 254mm, 305mm)
Core Size: Roll holders from 1.1" to 2.6" (27-66mm) with proprietary options

Roll Dimensions

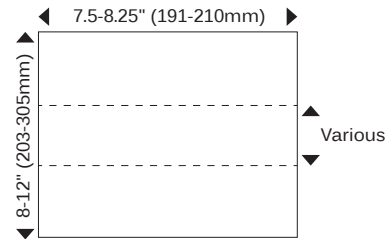

Shipping Specifications:

Weight in Case: 5 lbs (2.25kg)
Case Dimensions (L x W x H): 14 7/8" x 11 3/4" x 10 1/4" (378mm x 298mm x 260mm)
Units per Case: 1

North America:

Cases/Pallet*: 90
Weight/Pallet*: 465 lbs (211kg)

International:

Cases/Pallet*: 81
Weight/Pallet*: 420 lbs (191kg)

SKU: **AS108-05**

*Subject to change to maximize container load

Shipping Configurations

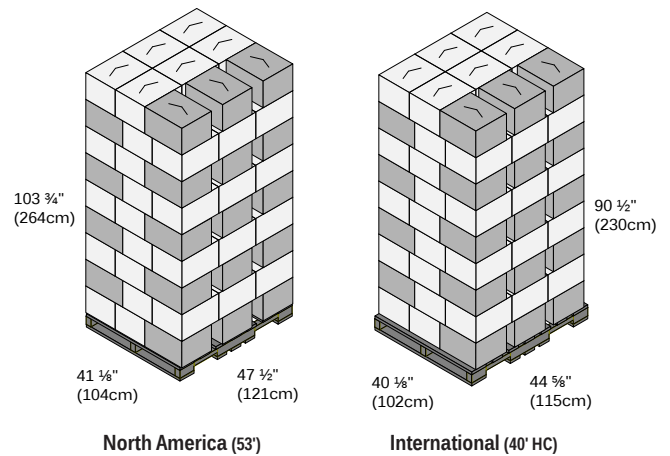

Dispensing solutions to grow your business!

We offer the widest array of options in the industry, customizing solutions to give you the functional capabilities, proprietary lock-out features, and aesthetic choices to support your business strategy.

Start dispensing value today!
www.DispensingDynamics.com



DISPENSING DYNAMICS
A Hunter Industries Company

Corporate Headquarters
1940 Diamond Street
San Marcos, CA 92078
U.S.A.

+1 800-888-3698
+1 626-961-3691