

Electronic Smoothcut™ Roll Towel Dispenser

Sensor dispensing with manual override technology

KEY OPERATING FEATURES

No Touch:	Hygienic hands-free operation
Cutting System:	Patented Smoothcut™ with adjustable delay, paper length, and sensing range
Paper Mode:	Exposed or Hidden
Activation:	Electronic with manual override
Manual Override:	Push bar or turn knob options

CAPACITY

Roll Width:	Standard 8.0" (203mm); accommodates from 7.5" to 8.25" (191mm to 210mm)
Roll Diameter:	Up to 8" (203mm)
Sheet Length:	Adjustable to 8" (203mm); 10" (254mm) and 12" (305mm)

CONSTRUCTION

Roll Holder:	Proprietary options
Modularity:	Interchangeable with mechanical Smoothcut module
Locks:	Push button, "T-Key", or proprietary keys
Material:	Impact and chemical resistant plastic

ADDITIONAL FEATURES

- Easy load battery box (4 D-cell batteries)
- AC adaptable
- Custom branding options available



AS108-05
Push Bar



AS108-05
Turn Knob



Leading edge EMS (Electronic Modular Smoothcut) module incorporates patented optical sensing and manual override technology for the industry's broadest range of customized dispensing options

AS108-05

Electronic Smoothcut™ Roll Towel Dispenser

Hygienic hands-free operation with the wide array of custom-dispensing options

Dispenser Specifications:

Finish/Color: White cover and back housing
Black cover and back housing
Smoke or clear window options

Manual overrides: Push bar override shown;
turn knob also available

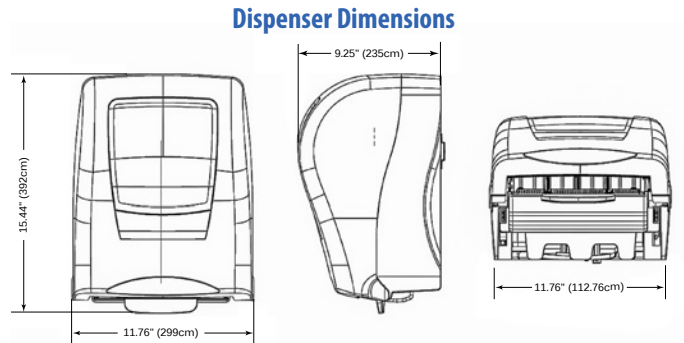

Paper Specifications:

Paper Capacity: 1 roll + stub roll
Roll Width: 7.5-8.25" (191-210mm)
Roll Diameter: 8.0" (203mm)
Roll Sheet: 8", 10", 12" (203mm, 254mm, 305mm)
Core Size: Roll holders from 1.1" to 2.6" (27-66mm) with proprietary options

Roll Dimensions

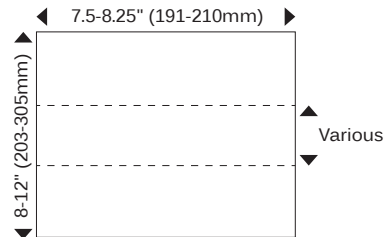

Shipping Specifications:

Weight in Case: 5 lbs (2.25kg)
Case Dimensions (L x W x H): 14 7/8" x 11 3/4" x 10 1/4" (378mm x 298mm x 260mm)
Units per Case: 1

North America:

Cases/Pallet*: 90
Weight/Pallet*: 465 lbs (211kg)

International:

Cases/Pallet*: 81
Weight/Pallet*: 420 lbs (191kg)

SKU: **AS108-05**

*Subject to change to maximize container load

Shipping Configurations

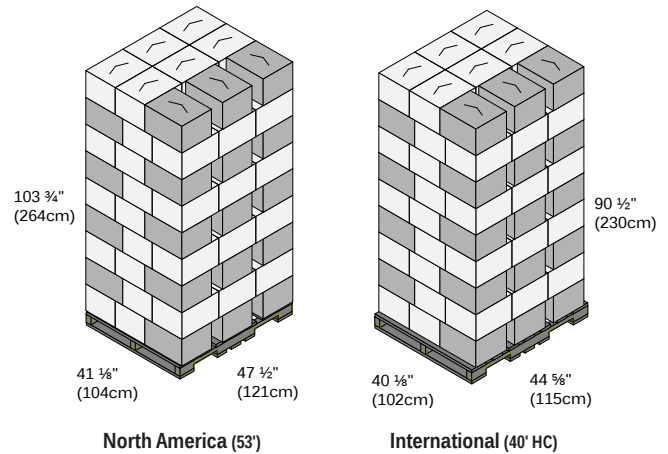

Dispensing solutions to grow your business!

We offer the widest array of options in the industry, customizing solutions to give you the functional capabilities, proprietary lock-out features, and aesthetic choices to support your business strategy.

Start dispensing value today!
www.DispensingDynamics.com



**DISPENSING
DYNAMICS**
A Hunter Industries Company

Corporate Headquarters
1940 Diamond Street
San Marcos, CA 92078
U.S.A.

+1 800-888-3698
+1 626-961-3691