

# Center Pull Towel Dispenser

**Hygienic center pull dispensing that's adjustable to all grades of paper from single ply tissue to industrial wipers**

## KEY OPERATING FEATURES

**Aperture:** Fixed funnel, fixed cleat, or self-adjusting for use with perforated paper

**Wet Wipe:** Top and bottom dispense options

## PAPER SIZE

**Roll Diameter:** 9.0" (229mm)

## CONSTRUCTION

**Material:** Tough, easy to clean industrial plastic

**Hinge:** Hidden, side hinged for easy loading

**Locks:** Generic, fixed or proprietary key available

## ADDITIONAL FEATURES

- Ideal for HACCP (Hazard Analysis and Critical Control Points) applications in foodservice, cosmetics and pharmaceuticals
- Adapts to 1 ply, 2 ply, airlaid and wipers
- Clear design to gauge level



**CP109-05  
White**



**CP109-05  
Black**



*Convenient one-handed loading*

*Unique split funnel with automatic tensioning works with any grade of towel or wiper provides option to accelerate dispensing*

**CP109-05**

# Center Pull Towel Dispenser

Hygienic center pull dispensing that's adjustable to all grades of paper from single ply tissue to industrial wipers

**Dispenser Specifications:**

Finish/Color:            White cover and back housing  
                                  Black cover and back housing

**Dispenser Dimensions**

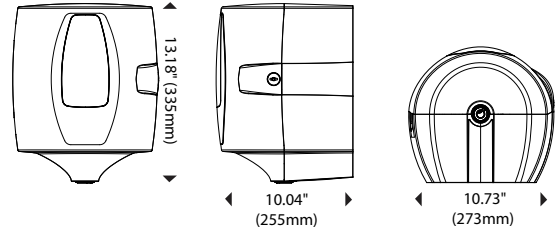

**Paper Specifications:**

Paper Capacity:        1 roll  
 Roll Height:            10.0" (254mm)  
 Roll Diameter:        9.0" (229mm)  
 Roll Sheet:            Variable (perforated)

**Roll Dimensions**



**Shipping Specifications:**

Weight in Case:        3.8 lbs (1.7kg)  
 Case Dimensions  
 (L x W x H):            13 7/16" x 10 1/4" x 11 3/16"  
                                  (341mm x 260mm x 284mm)  
 Units per Case:        1  
**North America:**  
 Cases/Pallet\*:        108  
 Weight/Pallet\*:       455.4 lbs (206.6kg)  
**International**  
 Cases/Pallet\*:        96  
 Weight/Pallet\*:       409.8 lbs (185.9kg)  
 SKU:                    **CP109-05**

**Shipping Configurations**

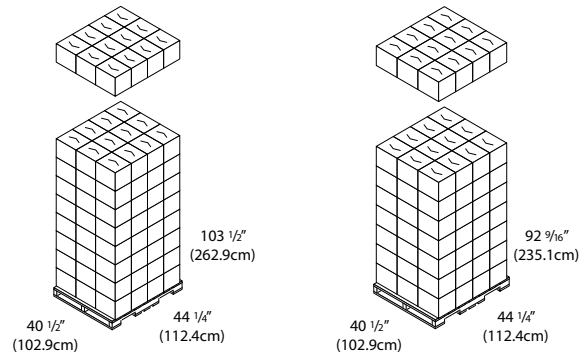

**North America**

**International**

\*Subject to change to maximize container load

**Dispensing solutions to grow your business!**  
 We offer the widest array of options in the industry, customizing solutions to give you the functional capabilities, proprietary lock-outs features, and aesthetic choices you need to support your business strategy.



**Start dispensing value today!**  
[www.DispensingDynamics.com](http://www.DispensingDynamics.com)



**Corporate Headquarters**  
 1020 Bixby Drive  
 City of Industry, CA 91745  
 U.S.A.  
**(1) 800-888-3698**

**International Sales Office**  
 19440 Enterprise Way  
 Surrey, BC V3S 6J9  
 Canada  
**(1) 888-225-7380**