

Smoothcut™ Mechanical Roll Towel Dispenser

Features ultra-quiet Mechanical Hands Free technology
— no batteries required!

KEY OPERATING FEATURES

- Hands-Free:** Pull exposed paper downwards with two hands. No touching of the housing required
- Cutting System:** The exclusive Smoothcut dispenses a wide range of papers with low pull force and consistent sheet length
- Emergency Feed:** Available with push bar or turn knob option for emergency paper feed

CAPACITY

- Roll Width:** Standard 8.0" (203mm); accommodates from 7.5" to 8.25" (191mm to 210mm)
- Roll Diameter:** Compact design holds up to 8" (203mm)
- Sheet Length:** Shorter 10" (254mm) sheet length provides more sheets per roll for paper savings

CONSTRUCTION

- Roll Holder:** Supports core sizes from 1.1" to 2.6" (28-66mm) with proprietary options
- Modularity:** Interchangeable with EMS electronic Smoothcut module
- Locks:** Push button and "T-Key"
- Material:** Impact and chemical resistant plastic

ADDITIONAL FEATURES

- Available in black and white cover and base
- Custom color and branding options available



HS108-00
Push Bar



HS108-00
Turn Knob

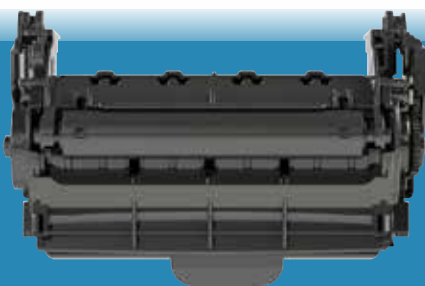

The patented module cuts a wide range of papers with low pull force and consistent sheet length

HS108-00

Smoothcut™ Mechanical Roll Towel Dispenser

Hygienic hands-free operation cuts a wide range of papers

Dispenser Specifications:

Finish/Color Options:

| COVER COLOR | BACK COLOR |
|-------------------|------------|
| BLACK SMOKE | WHITE |
| BLUE SMOKE | BLACK |
| TRANSLUCENT WHITE | |

Manual overrides: Push bar override shown; turn knob also available

Dispenser Dimensions

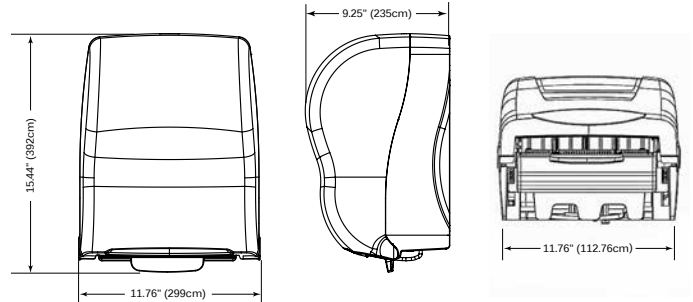

Paper Specifications:

Paper Capacity: 1 roll
 Roll Width: 7.5-8.25" (191-210mm)
 Roll Diameter: 8.0" (203mm)
 Roll Sheet: 8", 10", 12" (203mm, 254mm, 305mm)
 Core Size: Roll holders from 1.1" to 2.6" (27-66mm) with proprietary options

Roll Dimensions

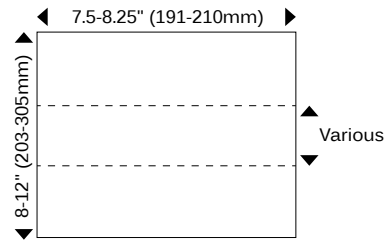

Shipping Specifications:

Weight in Case: 4.92 lbs (2.23kg)
 Case Dimensions (L x W x H): 14 7/8" x 11 3/4" x 10 1/4" (378mm x 298mm x 260mm)
 Units per Case: 1

North America:

Cases/Pallet*: 90
 Weight/Pallet*: 483 lbs (219kg)

International:

Cases/Pallet*: 81
 Weight/Pallet*: 429 lbs (223.8kg)

SKU: **HS108-00**

*Subject to change to maximize container load

Shipping Configurations

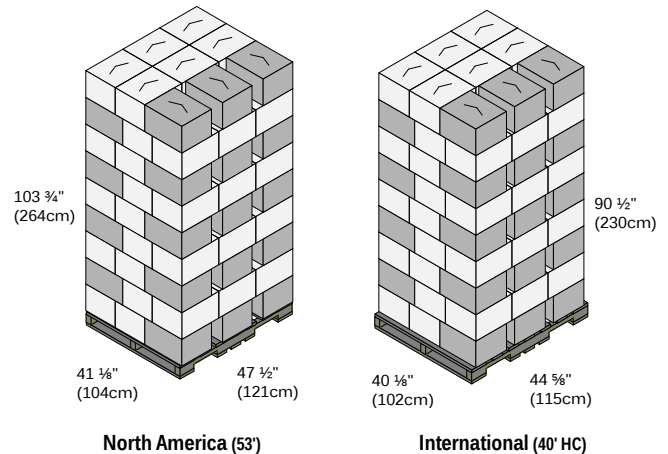

Dispensing solutions to grow your business!

We offer the widest array of options in the industry, customizing solutions to give you the functional capabilities, proprietary lock-out features, and aesthetic choices to support your business strategy.

Start dispensing value today!
www.DispensingDynamics.com



**DISPENSING
DYNAMICS**
 A Hunter Industries Company

Corporate Headquarters
 1940 Diamond Street
 San Marcos, CA 92078
 U.S.A.

+1 800-888-3698
+1 626-961-3691